

## Product description

The splitband amplifiers HS004, HS004L, HS004T are intended for amplifying cable TV, terrestrial TV and FM radio signals. There is a possibility to adjust the gain and slope of the amplifier separately in VHF and UHF bands. The amplifiers can provide power (+12 V) to external equipment through RF IN connector (1). The UHF sub-band of the HS004L, HS004T amplifiers have integrated 30 dB LTE signal suppression filter . The housing of amplifiers meets more stringent screening requirements according to EN50083-2, class A. According to the standard ETSI EN 303 354 V.1.1.1, type of these amplifiers is Launch, selectivity classification 0. The amplifiers are intended for indoor use only.

## Safety instructions

Installation of the amplifier must be done according IEC60728-11 and national safety standards. The amplifier is powered from mains 230 V~. This voltage is dangerous to life. Any repairs must be done by a skilled personnel. Do not remove the cover of the power supply section, without disconnecting the unit from the mains supply. Do not plug the amplifier into the mains supply if the power cord or plug is damaged. Do not plug the amplifier into the mains supply until all cables have been connected correctly. To disconnect the amplifier from the mains completely, disconnect plug from the mains socket. The mains socket must be easily accessible. The amplifier shall not be exposed to dripping or splashing water and no objects filled with liquids, such as vases, shall be placed on it. Avoid placing amplifier next to central heating components, near highly combustible materials and in areas of high humidity. No naked flame sources, such as lighted candles, should be placed on amplifier. If the amplifier has been kept in cold conditions for a long time, keep it in a warm room no less than 2 hours before plugging into the mains. Do not insert any objects into ventilation openings; The ventilation should not be impeded by covering the ventilation openings with items, such as newspapers, table-cloths, curtains. Mount the amplifier on not flammable wall or in not flammable installation box in vertical position with RF input connector underneath. The amplifier must be fixed with steel screws Ø 4-5 mm. The screws are not included in a package. From top, front and bottom of installed amplifier must be at least 10 cm free space.

## External view

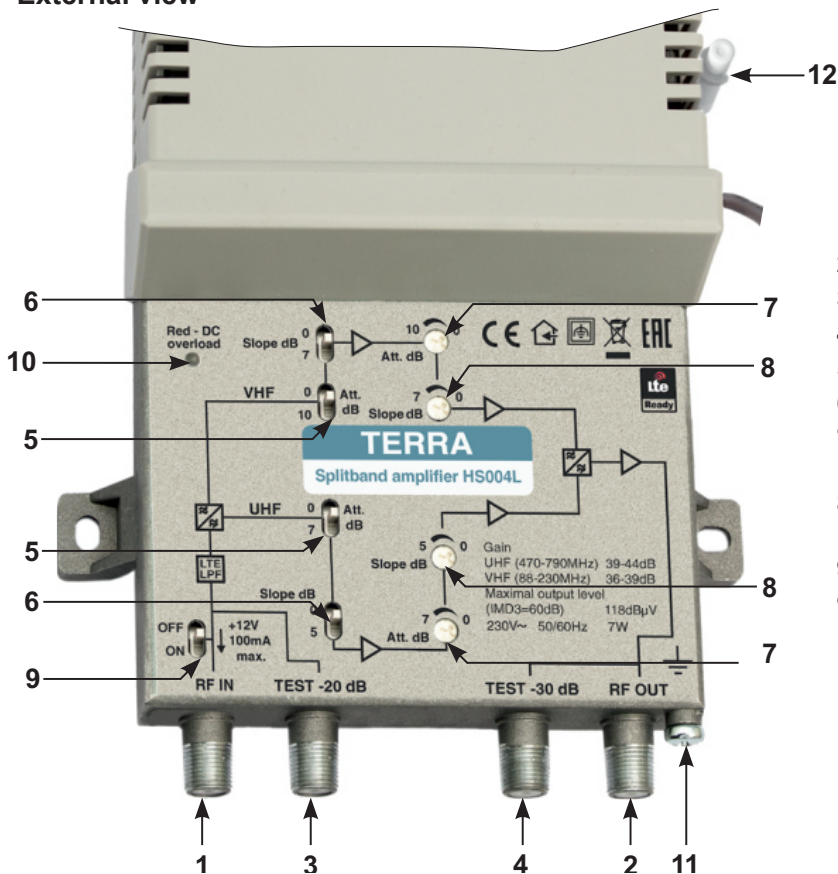



1. RF IN - RF signal input, DC output connector
2. RF OUT - RF signal output connector
3. TEST -20 dB
4. TEST -30 dB
5. gain (attenuation) switches for each sub-band
6. slope (attenuation) switches for each sub-band
7. fine tuning gain (attenuation) regulators for each sub-band
8. slope (attenuation) fine tuning regulators for each sub-band
9. switch to turn on/off the power feed for external equipment
10. powering indicator
11. functional ground clamp
12. screwdriver

## INSTALLATION INSTRUCTIONS

Read the product description and safety instruction first. Installation of system according standard IEC60728-11 ensures safety of personnel and prevents apparatus against damaging due to lightning or other sources of overvoltage surges. Gain of every sub-band can be adjusted with screwdriver (12). There is a possibility to adjust the gain and slope of the amplifier in every sub-band by fine turning 10 dB regulators (7, 8) and an additional 10 dB by switching switches (5, 6) in VHF and UHF bands. Power feed for external equipment is turned on and off by switch (9). It has short circuit and overload protection. In normal conditions powering indicator (10) glows green. If short circuit or overload in external powered equipment is detected - glows red.







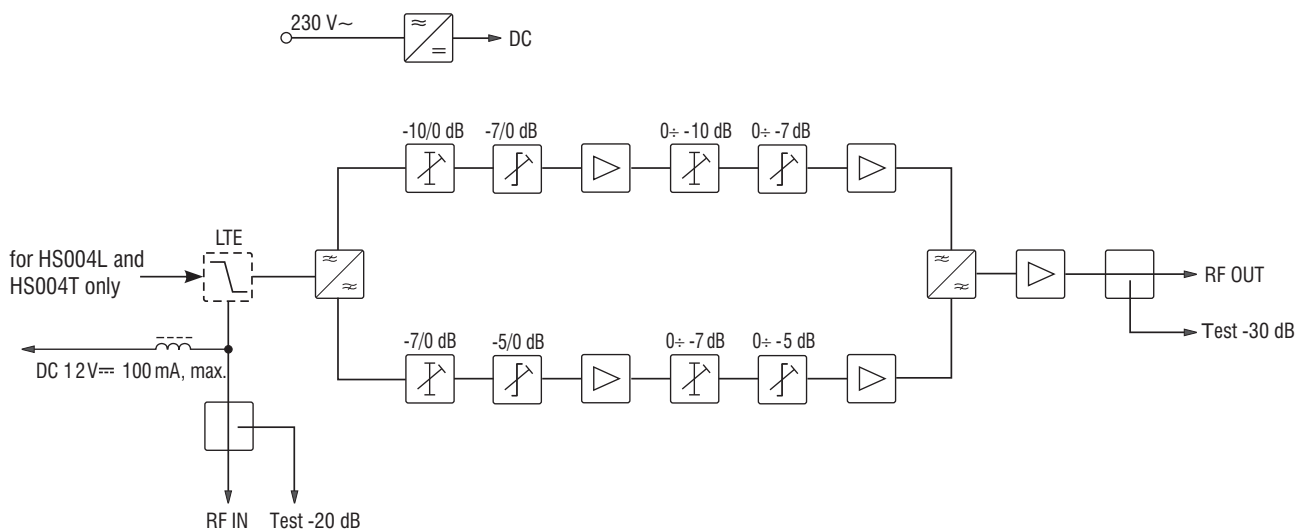

## Technical characteristics

		HS004		HS004L		HS004T	
Frequency range		VHF 47-414 MHz	UHF 470-862 MHz	VHF 88-230 MHz	UHF  470-790 MHz	VHF 88-230 MHz	UHF  470-694 MHz
Gain		34-39 dB	39-44 dB	36-39 dB	39-44 dB	36-39 dB	39-44 dB
Flatness		± 1 dB					
Gain adjustment		20 dB	14 dB	20 dB	14 dB	20 dB	14 dB
Slope adjustment		20 dB	10 dB	14 dB	10 dB	14 dB	10 dB
Maximal output level	IMD3=60 dB (DIN45004B)	121 dB $\mu$ V					
	IMD3=60 dB	118 dB $\mu$ V					
Input and output return loss		> 10 dB					
Noise figure		< 6 dB		< 6 dB	< 6 dB (700 MHz)	< 6 dB	< 6 dB (600 MHz)
Test points		input -20 dB, output -30 dB					
DC output for external equipment		12 V $\overline{=}$ 100 mA max.					
Supply voltage limit values, power consumption*		198-250 V~ 50/60 Hz 7 W					
Operating temperature range		-20° ÷ +50° C					
Dimensions/Weight (packed)		135x180x52 mm/0.7 kg					

\* with external DC loading

## Structure diagram



-  Caution.
-  Risk of electric shock.
-  This product complies with the relevant clauses of the European Directive 2002/96/EC. The unit must be recycled or discarded according to applicable local and national regulations.
-  Equipment intended for indoor usage only.
-  Equipment is double insulated from the mains, with functional earthing.
-  Functional earthing. Connect to the main potential equalization.
-  The device has integrated LTE filter.
-  This product is in accordance with following norms of EU: EMC norm EN50083-2, safety norm EN62368-1 and RoHS norm EN50581.
-  This product is in accordance with Custom Union Technical Regulations: "Electromagnetic compatibility of technical equipment" CU TR 020/2011, "On safety of low-voltage equipment" CU TR 004/2011.